

PC-F1 Self tapping female (page 1 of 2)

	<p>USE WITH:</p> <p>PC-M1A PC-M2H VS-M1</p> <p>PC-SM2 PC-SM2H</p> 	<p>INSTALL WITH:</p> <p>CT-01 CT-03 CT-07 CT-10</p> 
<p>INSTALLATION STEPS <small>(see reverse for more options)</small></p>		

<p>1 Drill hole through panel & frame</p> 	<p>2 Drill out frame hole with CT-07</p> 	<p>3 Screw fit PC-F1 with CT-03</p> 
---	--	---

4 Screw fit PC-F1 into thin frame

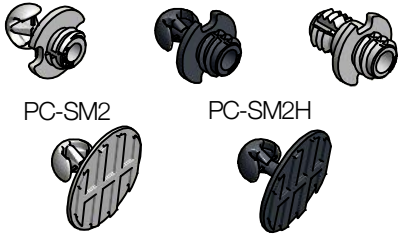
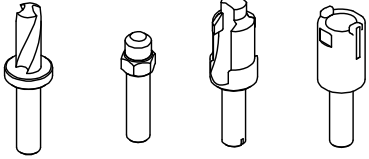
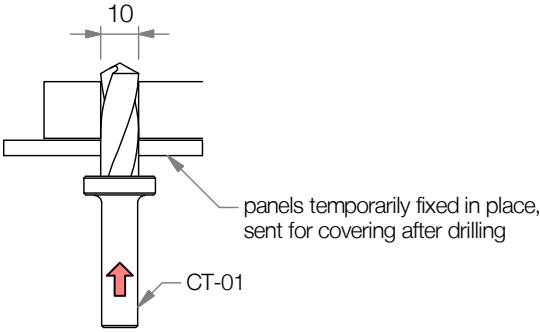
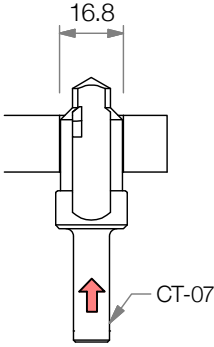
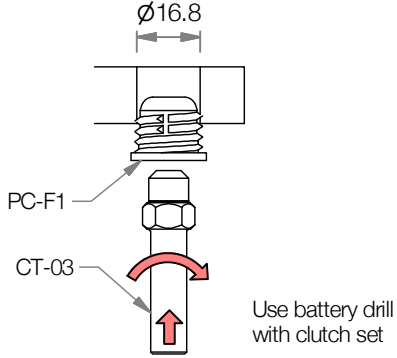
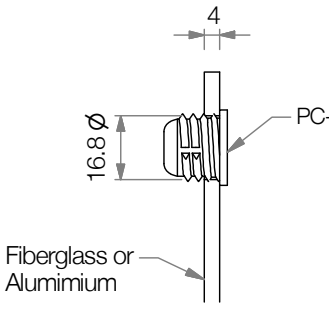

5 Cutaway view showing panel mounting

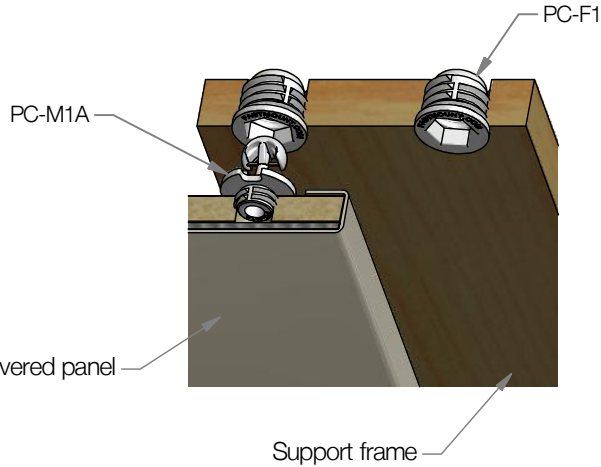

PC-F1 can be used as screw / friction fit into thin frames & seat backs

PC-F1 Self tapping female (page 2)

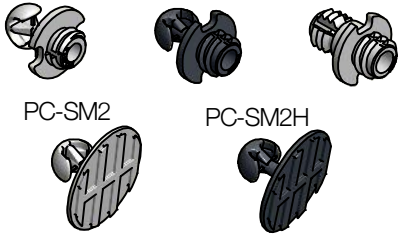
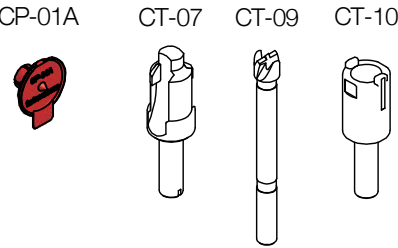
	<p>USE WITH:</p> <p>PC-M1A PC-M2H VS-M1</p> <p>PC-SM2 PC-SM2H</p> 	<p>INSTALL WITH:</p> <p>CP-01A CT-07 CT-09 CT-10</p> 
<p>INSTALLATION STEPS <small>(continued from previous page)</small></p>		

1 Fit CP-01A into PC-F1 then push panel to mark center

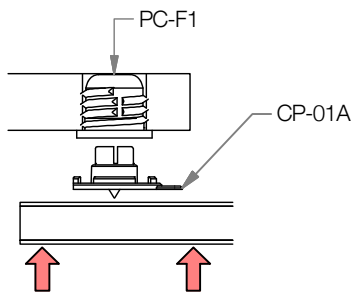

2 Drill panel on center mark with CT-09 7.5mm deep

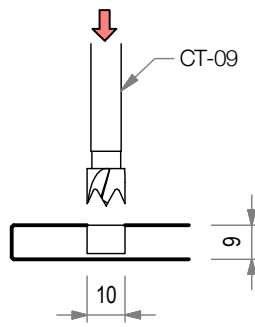

3 Screw fit male clip with CT-10

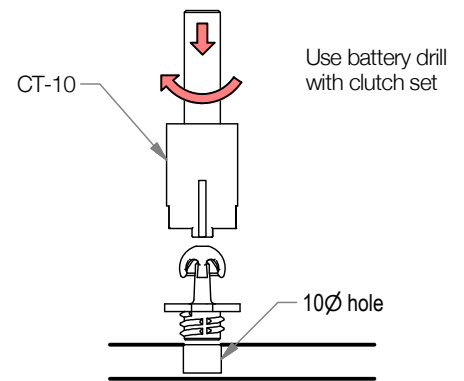

INSTALLING ADHESIVE FIT MALE CLIPS (first complete steps 1 to 3, page 1)

4 Clip PC-SM2 into PC-F1

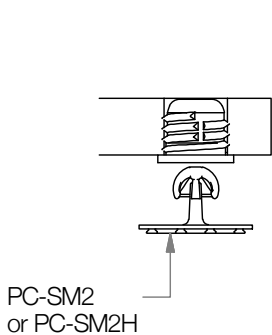

5 Apply adhesive to PC-SM2

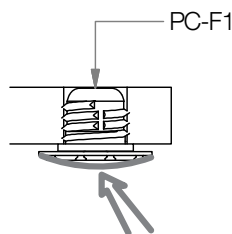

6 Place panel & support while adhesive dries

